

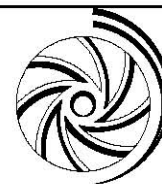

Price® Pump Co.



INSTALLATION, OPERATING AND MAINTENANCE MANUAL

AIR OPERATED
DIAPHRAGM PUMPS
MODEL: AOD .25-Y
ALL ELASTOMERS

PLEASE FILL IN DATA
FROM YOUR PUMP
NAMEPLATE

Pump Model _____

Spec. No. _____

Serial No. _____

Seal No. _____

RETAIN MANUAL
FOR REFERENCE

Price® Pump Company
P.O.Box Q
Sonoma, CA 95476
Tel: 707-938-8441
Fax: 707-938-0764
Email: sales@pricepump.com

IN-AOD-Y-.25

REV-A 06/22/07

Table of Contents

Warnings and Cautions	1
Table of Contents	2
1. Principle of operation	3
2. Tools, etc.	
2.1 General tools	3
2.2 Special Tools	3
2.3 Misc.	3
3. Ordering Replacement Parts.....	3
4. Balls, Flat valves and Valve Seats	
4.1 Removal	
FAT, FST types	4
FP_, FV_ types	5
4.2 Inspection	6
Flat Valve types	6
4.3 Installation	6
5. Diaphragm and Center rod	
5.1 Removal FAT, FST types	7
FPT, FVT type	8
5.2 Inspection	8
5.3 Installation	
F_T types	9
6. Pilot valve assembly, Guide bushing	
6.1 Removal	9
6.2 Inspection	10
6.3 Installation	10
7. C Spool valve assembly and Sleeve Assembly	
7.1 Removal	10
7.2 Inspection	11
7.3 Installation	11
8. Exploded View and Parts List	
8.1 FAT, FST	12
8.2 FPT FVT	15

1. Principles of operation

There are two diaphragms fixed to the center rod, one at each end. When compressed air is supplied to air chamber b (right side, see Fig. 1.1), the center rod moves to the right, the material in material chamber B is pushed out, and at the same time material is sucked into material chamber A. When the center rod is moved full-stroke to the right, the air switch valve is switched, compressed air is sent to air chamber a (left side, see Fig. 1.2), and the center rod moves to the left. The material in material chamber A is pushed out, and at the same time material is sucked into material chamber B. Through repetition of this operation, material is repeatedly taken in and discharged out.

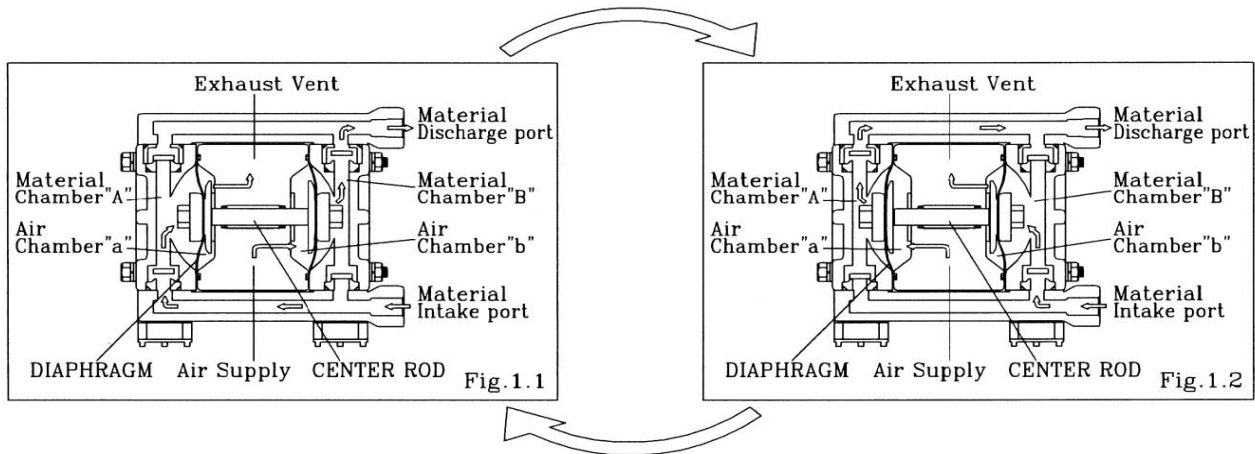

2. Tools, etc.

2.1 General tools

- Socket wrenches 10 mm
- Open-end wrenches 10 mm
- Pliers

2.2 Special tools

- Accessory tool (included)
Purpose: Removing the center disk of FPT and FVT types

- Sleeve remover (sold separately)
Purpose: For removing sleeves

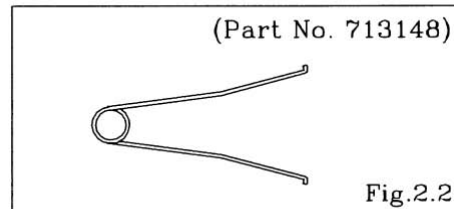
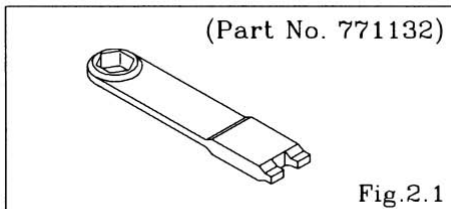

2.3 Misc.

- Assembly oil Turbine oil none addition class 1 (equivalent ISO VG32 grade).
- Nuts M 6x1.

2.3. Ordering Replacement parts

For accurate and speedy shipment of parts, be sure to order the right parts for your model to your distributor.

Indicate the part numbers, descriptions and quantities.

4. Balls, Flat valves and Valve Seats

4.1 Removal

FAT, FST types

See [8. Exploded View] on after p.12 (Fig. 4.1, 4.2, 4.3 and 4.4).

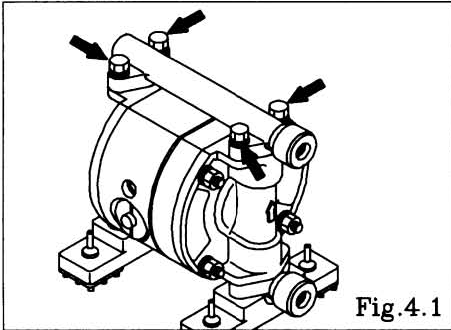

- Remove the 4 retainer bolts from the out manifold, and remove the out manifold. [Fig. 4.1]

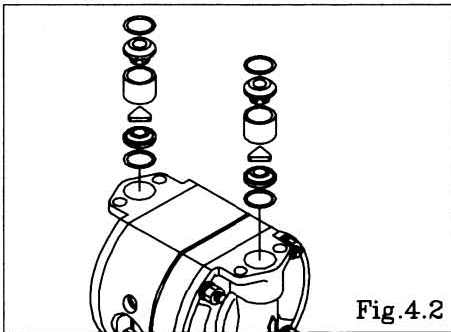

- Remove the O ring, valve stopper, valve guide, flat valve and valve seat. [Fig. 4.2]

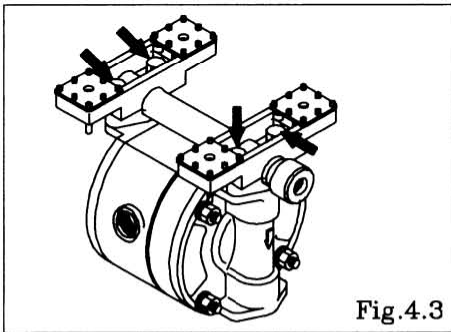

- Turn over the main body assembly. [Fig. 4.3]
- Remove the 4 retainer bolts from the in manifold, and remove the in manifold. [Fig. 4.3]

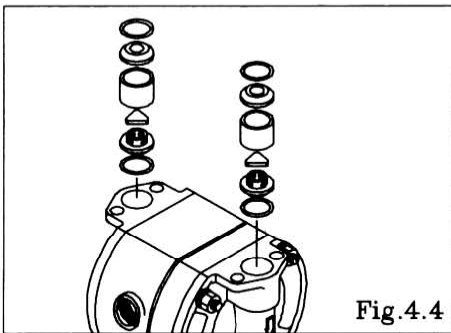

- Remove the O ring, valve seat, flat valve, valve guide and valve stopper. [Fig. 4.4]

FPT, FVT types

See [8. Exploded View] on after p.12 (Fig. 4.5, 4.6, 4.7 and 4.8).

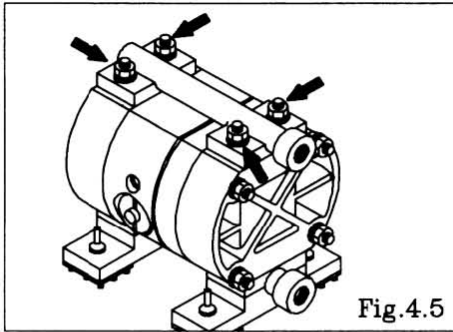

- Remove the 4 retainer nuts from the out manifold, and remove the out manifold. [Fig. 4.5]

<NOTE>

- When the retainer nuts are removed from the tie rods, the in manifold removes.

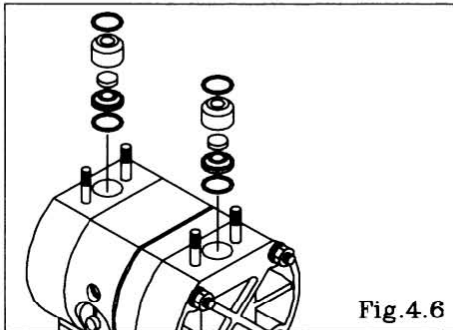

- Remove the O ring, valve stopper, flat valve and valve seat. [Fig. 4.6]

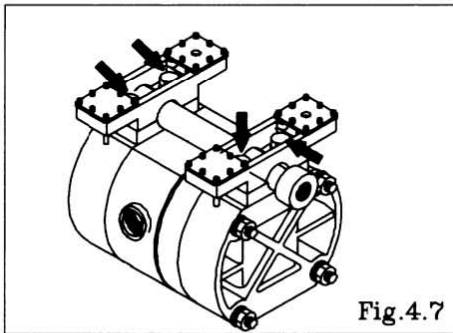

- Turn over the main body assembly. [Fig. 4.7]
- Pull out the bolt, and remove the base and in manifold.

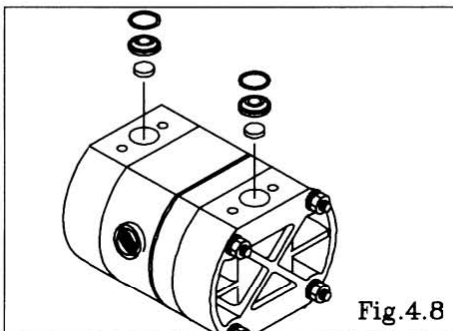

- Remove the O ring, valve seat, flat valve. [Fig. 4.8]

4.2 Inspection: Flat valve type

- Flat valve [Fig. 4.9]

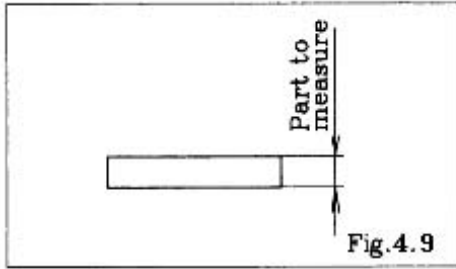

Measure the dimension shown at left, and if it is outside the usable range, replace the seat. If the seal ring is worn out or cracked, replace it.

Usable range of Flat valve

0.098 ~ 0.122 in {2.5 ~ 3.1 mm}

- Valve seat [Fig 4.10]

Measure the dimension shown at left, and if it is outside the usable range, replace the seat.

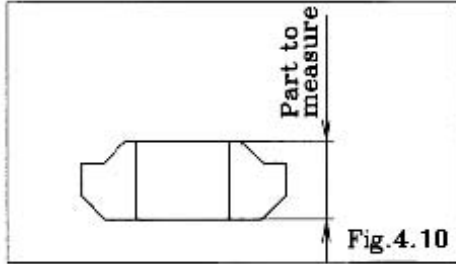

Usable range of Valve seat

0.228 ~ 0.280 in {5.8 ~ 7.1 mm}

- O ring (other than PTFE)

If O rings are worn out or cracked, replace them.

4.3 Installation

For installation, see [8. Exploded View] on after p.12, and install in the reverse order of disassembly.

Tightening torque for manifold retainer bolts

65 lbf ·in {75 kgf ·cm}

<NOTE>

- Make sure there is no dust on the seal surface and the seal is not damaged.
- Replace the PTFE O ring regardless of its condition.

5. Diaphragm and Center rod

5.1 Removal; FAT, FST types

See [8. Exploded View] on after p.12.

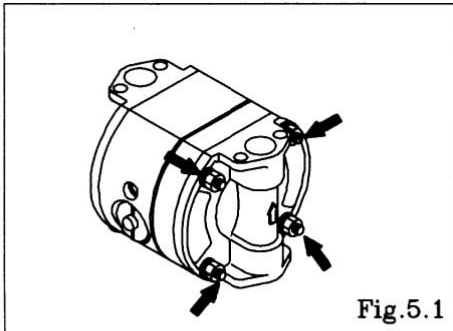

- Remove the ball and flat valve and valve seat (see [4.1 removal FAT, FST types] on p.4). Remove the 8 retainer bolts from the out chamber, and remove the out chamber. [Fig. 5.1]

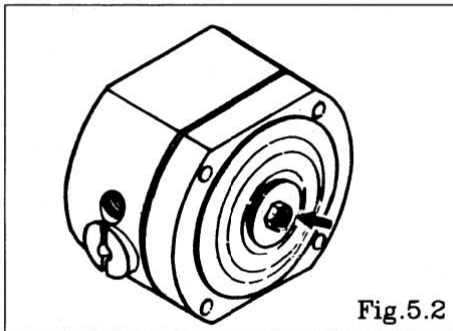

- Remove the nuts on both sides of the center rod. [Fig. 5.2] After the nuts on one side have been removed, remove center disk and diaphragm. Remove the diaphragm, center disk and center rod from the opposite side of the main body.

<NOTE>

- When the diaphragms are removed, the main body is separated in 2 pieces. For easy work, leave the tie rods or bolts fastened temporarily before removing the diaphragms.

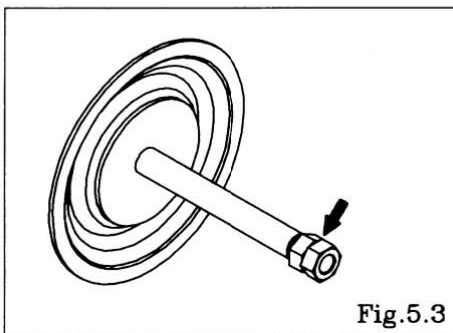

- Remove the nuts on the opposite side using the double nuts. [Fig. 5.3]
- Remove the coned disk spring, center disk and diaphragm.

FPT, FVT types

See [8. Exploded View] on after p.12.

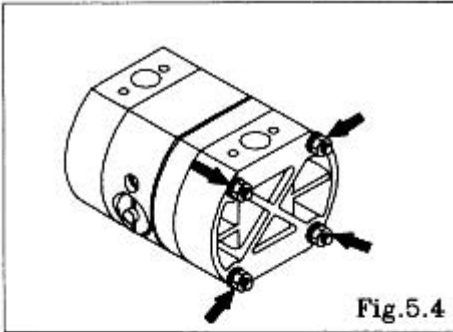

- Remove the flat valve and valve seat.

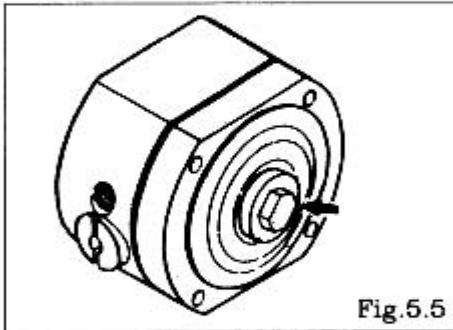

- Remove the center disk from one side using the accessory tool (special tool: part No. 771132). [Fig. 5.5]
- After the center disk (outside) has been removed, remove the diaphragm and the center disk (inside).
- Remove the center disk and center rod from the opposite side of the main body.

<NOTE>

- When the diaphragm are removed, the main body is separated in 2 pieces. For easy work, leave bolts fastened temporarily before removing the diaphragm.
- Fix a double nut to one end of the center rod and take the diaphragm and center disk off the opposite end. [Fig. 5.6]
- Be careful not to scratch or score the center rod.

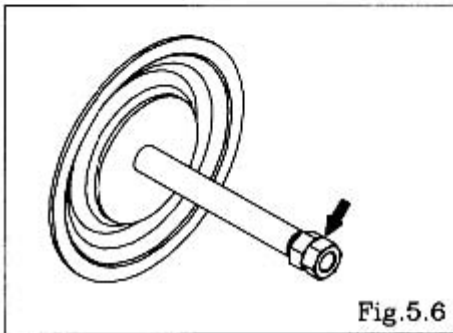

5.2 Inspection

- Diaphragm If the diaphragm is worn out or damaged, replace it. New replace just one diaphragm.

Guideline of diaphragm (estimated) life

PTFE ;30,000,000 Strokes

(When used with clean water at room temperature)

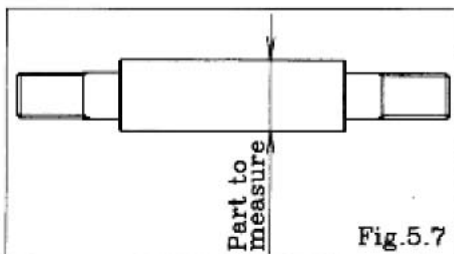

- Center rod [Fig. 5.7]
Measure the diameter, and if it is outside the usable range, replace the rod.

Usable range of center rod

$\varnothing 0.3917 \sim \varnothing 0.3937$ in { $\varnothing 9.95 \sim \varnothing 10.00$ mm}

5.3 Installation

F_T types

For installation, see [8. Exploded view] on after p.12, and install in the reverse order of disassembly.

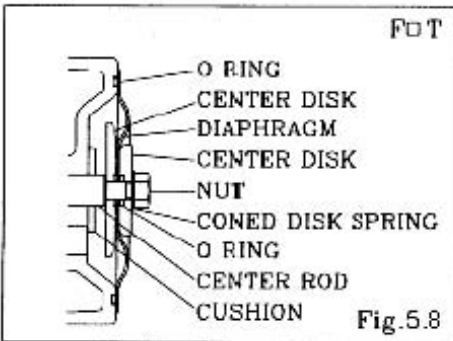

- Apply lubricating oil to the center rod, and insert it into the main body.
- Keep the marking “LIQUID” to liquid end for CR, NBR diaphragms.
- Keep the convex side to the outside for PTFE diaphragms.
- Install the O ring (cf. Fig. 5.8).
- Tighten the center disk using the accessory tool (special tool: part No. 771132).
- After installation of the out chambers on both sides, place the pump on a flat surface and stand the pump upright for further assembly.

Tightening torque for center rod and out chamber

65 lbf·in {75 kg·cm}

<NOTE>

- Make sure there is no dust on the seal surface in order to prevent seal damaged.
- Replace the PTFE O ring with a new one.
- Tighten the bolts that balance should be equal from both sides on diagonal line with even torque.

6. Pilot valve assembly, Guide and Bushing

6.1 Removal

See [8. Exploded View] on after p.12.

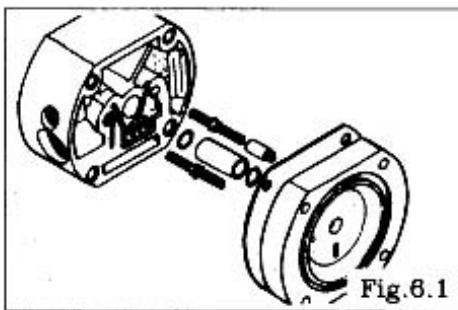

- Remove the diaphragm and center rod etc. (see [5.1 removal] on p.7).
- Remove the main body. [Fig. 6.1]
- Draw out the pilot valve assembly. [Fig. 6.1]
- Remove the O ring and bushing. [Fig. 6.1]

6.2 Inspection

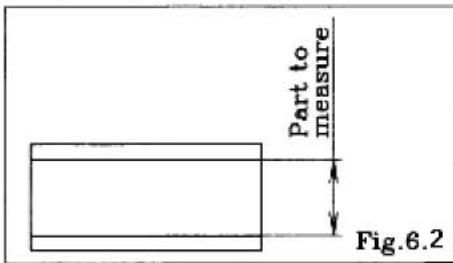

- Bushing [Fig. 6.2]
Measure the inside diameter, and if it is outside the usable range, replace the bushing.

Usable range of bushing

$\text{Ø}0.398 \sim \text{Ø}0.406$ in $\{\text{Ø}10.1 \sim \text{Ø}10.3\text{mm}\}$

- O rings
If O rings are worn out or cracked, replace them.
- Pilot valve assembly.
If the pilot valve is worn or cracked, replace it.

6.3 Installation

For installation, see [8. Exploded View] on after p. 12, and install in the reverse order of disassembly.

<NOTE>

- Make sure there is no dust on the seal surface and it is not damaged.

7. C spool assembly and sleeve assembly

7.1 Removal

See [8. Exploded View] on after p.12.

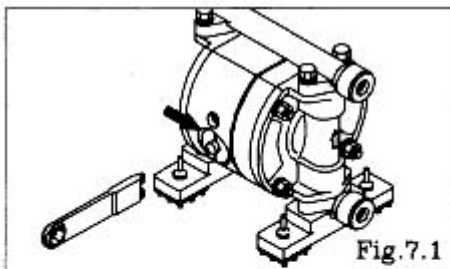

- Remove the cap using the accessory tool (special tool: part No. 771132). [Fig. 7.1]

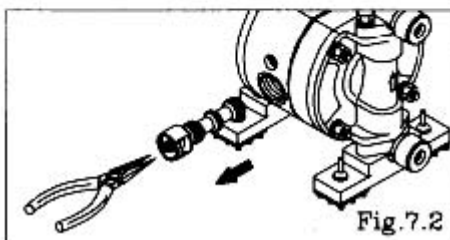

- Draw out the C spool valve assembly using the pliers, and remove the seal ring from the C spool valve assembly. [Fig. 7.2]

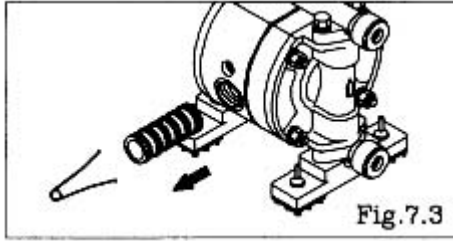

- Remove the sleeve using the sleeve remover (special tool: part No. 713148). [Fig. 7.3]

7.2 Inspection

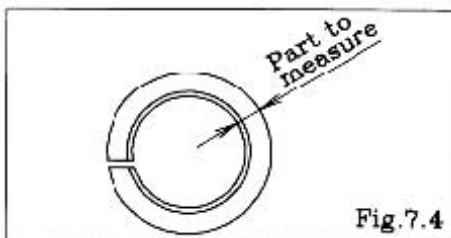

- C spool assembly
- Seal ring [Fig. 7.4] Measure the inside thick diameter, and if it is outside the usable range, replace the C spool assembly. If the seal ring is worn out or cracked, replace C spool assembly.

Usable range of seal ring

$\text{Ø}0.0551\sim\text{Ø}0.0571\text{in}\{1.40\sim1.45\text{mm}\}$

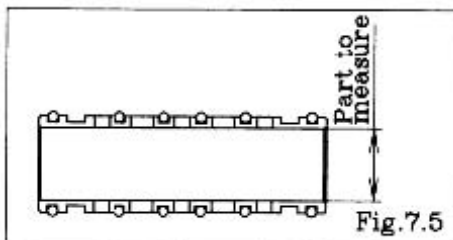

- Sleeve Assembly [Fig. 7.5] Measure the inside diameter, and if it is outside the usable range, replace the sleeve assembly.

Usable range of Sleeve

$\text{Ø}0.3740\sim\text{Ø}0.3760\text{in}\{9.50\sim9.55\text{mm}\}$

- O rings

If O rings are worn out or cracked, replace them.

<NOTE>

- C Spool assembly and sleeve assembly must be replaced by complete set. Unable to replace individual components.

7.3 Installation

For installation, see [8. Exploded View] on after p.12, and install in the reverse order of disassembly.

<NOTE>

- Make sure there is no dust on the seal surface and it is not damaged.

8.1 Exploded View FAT, FST

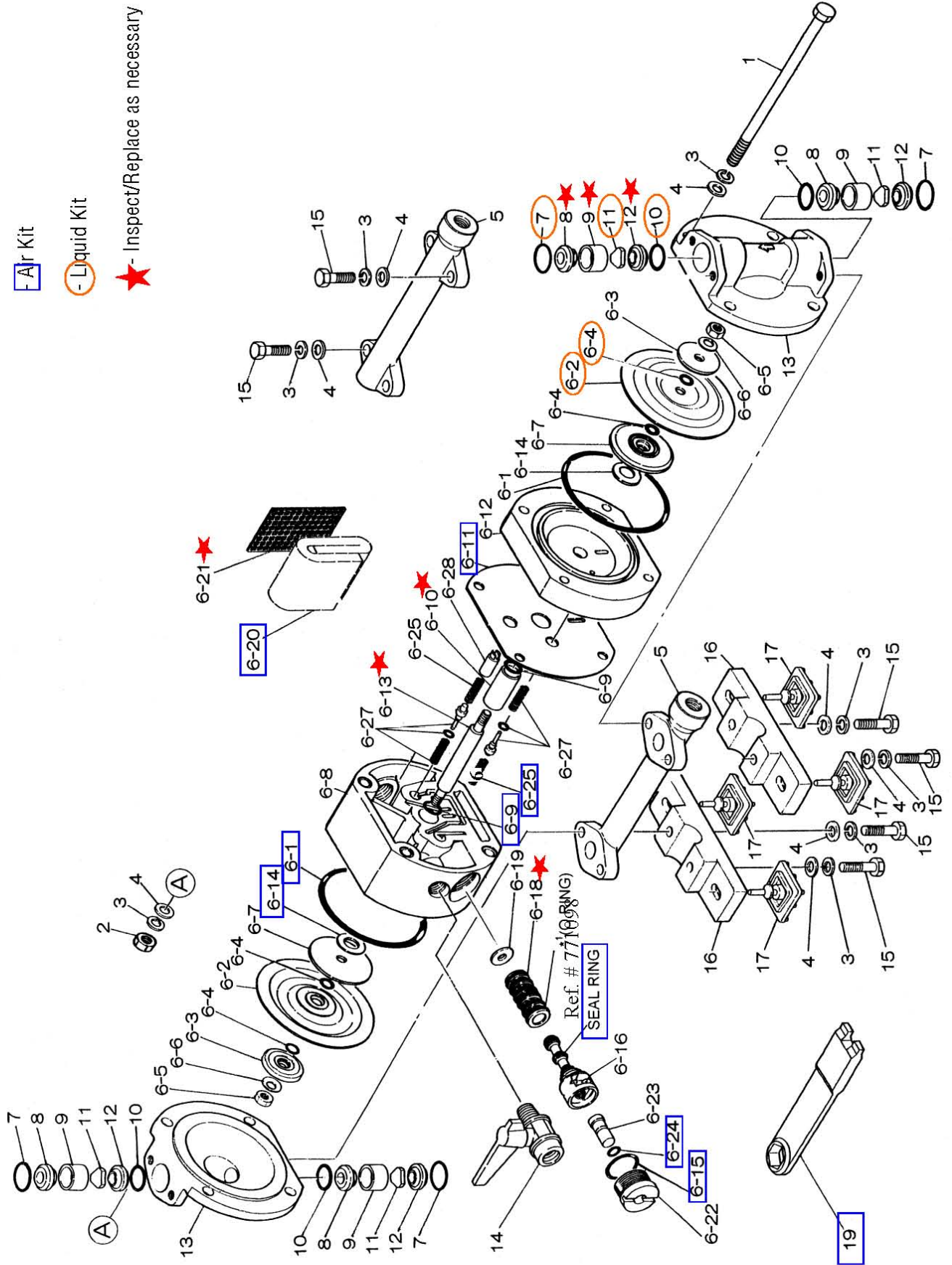

8.1 Parts List FAT, FST

NO.	FAT	FST	DESCRIPTION	QTY	NOTE
1	682528	682528	BOLT	4	M6x1x92
2	628010	628010	NUT	4	M6x1
3	681855	681855	SPRING LOCK WASHER	16	M6
4	631328	631328	PLAIN WASHER	16	M6
5	709657	831323	MANIFOLD	2	
			MANIFOLD ASSEMBLY	2	
6	802235	802236	BODY ASSEMBLY	1	
7	643015	643015	O’RING	4	P-16 PTFE
8	709364	709364	VALVE STOPPER	4	
9	709635	709635	VALVE GUIDE	4	
10	771133	771133	O’RING	4	
11	771152	771152	FLAT VALVE	4	
12	709637	709637	VALVE SEAT	4	
13	709469	709467	OUT CHAMBER	2	
14	683055	683055	BALL VALVE	1	1/4”
15	621103	621103	BOLT	8	M6x1x25
16	771101	771101	BASE	2	
17	771102	771102	CUSHION	4	
18	790911	790911	NAME PLATE	1	
19	771132	771132	ACCESSORY TOOL	1	

NOTE: NO. 18 (NAME PLATE) IS NOT INDICATED IN EXPLODED VIEW

802235, 802236 BODY ASSEMBLY

NO	FAT	FST	DESCRIPTION	QTY	NOTE
6-1	640139	640139	O'RING	2	G-70
6-2	771093	771093	DIAPHRAGM	2	
6-3	709477	709476	CENTER DISK	2	
6-4	643003	643003	O'RING	4	P-6 NBR
6-5	683391	683391	NUT	2	M6x1
6-6	684915	684915	CONED DISK SPRING	2	M6
6-7	709317	709317	CENTER DISK	2	
6-8	780006	780006	BODY A	1	
6-9	640007 685752	640007 685752	O'RING PACKING	2	P-10 NBR
6-10	771088	771088	BUSHING	1	
6-11	771980	771980	GASKET	1	
6-12	780001	780001	BODY B	1	
6-13	709316	709316	CENTER ROD	1	
6-14	771239	771239	CUSHION	2	
6-15	640017	640017	O'RING	1	P-20 NBR
6-16	802386	802386	C SPOOL VALVE ASSEMBLY	1	
6-18	803214	803214	SLEEVE ASSEMBLY	1	*1 (771097)
6-19	771096	771096	CUSHION	1	
6-20	771465	771465	SILENCER	1	
6-21	771589	771589	MESH	1	
6-22	771100	771100	CAP	1	
6-23	771099	771099	RESET BUTTON	1	
6-24	640002	640002	O'RING	1	P-5 NBR
6-25	709319	709319	SPRING	2	
6-26	803510	803510	PILOT VALVE ASSEMBLY	2	
6-28	771095	771095	STOPPER	1	

NOTE: *1: PART NUMBER MENTIONED ON O'RING FOR SLEEVE ASSEMBLY ONLY.

8.2 Exploded View FPT, FVT

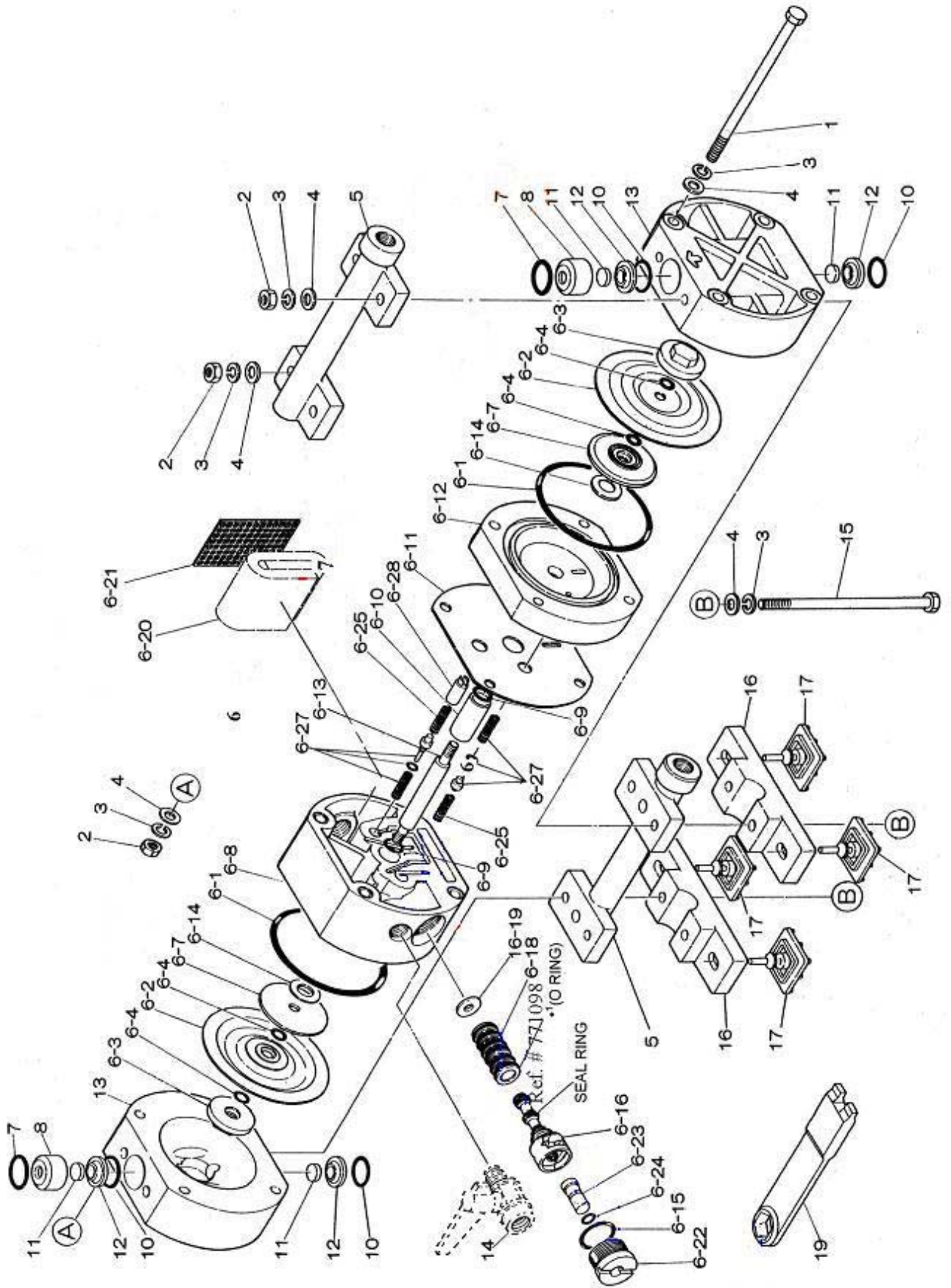

Parts List

Parts List FPT, FVT					
No.	FPT	FVT	Description	QTY	Notes
1	682748	682748	BOLT	4	M6x1x139.5
2	628010	628010	NUT	8	M6x1
3	681855	681855	SPRING LOCK WASHER	16	M6
4	631328	631328	PLAIN WASHER	16	M6
5	780133	780053	MANIFOLD	2	
6	802594	802797	BODY ASSEMBLY	1	
7	643015	643015	O'RING	6	P-16 PTFE
8	772655 (New)	771581	VALVE STOPPER	2	
9					
10	643013	643013	O'RING	4	P-14 PTFE
11	771094	771094	FLAT VALVE	4	
12	771112 772738 (New)	771582 772735 (New)	VALVE SEAT VALVE SEAT (for New Replaceable Valve Guides)	4	
13	771092 780231 (New)	771583 780232 (New)	OUT CHAMBER OUT CHAMBER (FOR New Replaceable Valve Guides)	2	
14	683055	683055	BALL VALVE	1	1/4"
15	682747	682747	BOLT	4	M6x1x127
16	771101	771648	BASE	2	
17	771102	771102	CUSHION	4	
18	790911	790911	NAME PLATE	1	
19	771132	771132	ACCESSORY TOOL	2	
20					

NOTE: NO. 18 (NAME PLATE) IS NOT INDICATED IN EXPLODED VIEW

Parts List

802594, 802797 BODY ASSEMBLY					
No.	FPT	FVT	Description	QTY	Notes
6-1	640139	640139	O'RING	2	G-70 NBR
6-2	771093	771093	DIAPHRAGM	2	
6-3	771089	771579	CENTER DISK	2	
6-4	643003	643003	O'RING	4	P-6 PTFE
6-5					
6-6					
6-7	709317	709317	CENTER DISK	2	
6-8	780006	780006	BODY A	1	
6-9	685752	685752	PACKING	2	
6-10	771088	771088	BUSHING	1	
6-11	771980	771980	GASKET	1	
6-12	780001	780001	BODY B	1	
6-13	709316	709316	CENTER ROD	1	
6-14	771239	771239	CUSHION	2	
6-15	640017	640017	O'RING	1	P-20 NBR
6-16	80238	802386	C SPOOL VALVE ASSY	1	
6-17					
6-18	803214	803214	SLEEVE ASSEMBLY	1	*1 (771097)
6-19	771096	771096	CUSHION	1	
6-20	771465	771465	SILENCER	1	
6-21	771589	771589	MESH	1	
6-22	771100	771100	CAP	1	
6-23	771099	771099	RESET BUTTON	1	
6-24	640002	640002	O'RING	1	P-5 NBR
6-25	709319	709319	SPRING	2	
6-26	803510	803510	PILOT VALVE ASSEMBLY	2	
6-27	771095	771095	STOPPER	1	

NOTE)*1: PARTS NUMBER MENTIONED ON O RING FOR SLEEVE ASSEMBLY ONLY.



1. GENERAL

A. Seller's price is based on these sales terms and conditions. The agreement and inclusion of other or amended terms in this contract will result in a change (including increase) in Seller's price (as may be contained in any price books or quotations) to reflect such other or amended terms. This contract shall represent the final, complete and exclusive statement of the agreement between the parties and may not be modified, supplemented, explained or waived by parole evidence, any Terms and Conditions contained in Buyer's purchase order or request for quotation, any course of dealings between the parties, Seller's performance or delivery, or in any other way. The Terms and Conditions of this contract may only be modified or waived in a written document signed by an Officer of Seller. These terms are intended to cover all activity of Seller and Buyer hereunder, including sales and use of products, parts and work and all related matters (references to products include parts and references to work include construction, installation and start-up). Any reference by Seller to Buyer's specifications and similar requirements are only to describe the products and work covered hereby and no warranties or other terms therein shall have any force of effect. Any information provided by Seller including, but not limited to, suggestions as to specific equipment does not imply any guarantee of specific suitability and/or material compatibility in a particular application, since many factors outside the control of Seller may affect the suitability of products in a particular application. Catalogs, circulars, similar pamphlets and information contained on websites of the Seller are issued for general information purposes only and shall not be deemed to modify the provisions hereof.

B. The agreement formed hereby and the language herein shall be construed and enforced under the Uniform Commercial Code as in effect in the State of California on the date hereof.

2. TAXES

Any sales, use or other similar type taxes imposed on this sale or on this transaction and/or any import or export duties or fees as may be assessed or imposed on or as a result of deliveries under this transaction are not included in the price. Such taxes shall be billed separately to the Buyer. Seller will accept a valid exemption certificate from the Buyer if applicable; however, if an exemption certificate previously accepted is not recognized by the governmental taxing authority involved and the Seller is required to pay the tax covered by such exemption certificate. Buyer agrees to promptly reimburse Seller for the taxes paid.

3. PERFORMANCE, INSPECTION AND ACCEPTANCE

A. Unless Seller specifically assumes installation, construction or start-up responsibility, all products shall be finally inspected and accepted within thirty (30) days after arrival at point of delivery. Where seller has responsibility for installation, construction or start-up all work shall be finally inspected and accepted within thirty (30) days after completion of the applicable work by Seller. All claims whatsoever by Buyer, (including claims for shortages) except only those provided for under the WARRANTY AND LIMITATION OF LIABILITY and PATENTS Clauses, hereof, must be asserted in writing by Buyer within said thirty (30) day period or they are waived. If this contract involves partial performance, all such claims must be asserted within said thirty- (30) day period for each partial performance. There shall be no revocation of acceptance. Rejection may be only for defects substantially impairing the value of products or work and Buyer's remedy for lesser defects shall be those provided for under the WARRANTY AND LIMITATION OF LIABILITY Clause.

B. Seller shall not be responsible for non-performance or for delays in performance occasioned by any causes beyond Seller's reasonable control, including, by way of example and not limitation, to labor difficulties, delays of vendors or carriers, fires, governmental actions, or shortages of material, components, labor, or manufacturing facilities. Any delays so occasioned shall affect a corresponding extension of Seller's performance dates, which are, in any event, understood to be approximate. IN NO EVENT SHALL BUYER BE ENTITLED TO INCIDENTAL OR CONSEQUENTIAL DAMAGES FOR LATE PERFORMANCE OR FOR A FAILURE TO PERFORM. Seller reserves the right to make partial shipments and to ship products, parts or work which may be completed prior to the scheduled performance date.

C. In the event that Seller has agreed to mount motors, turbines, gears, or other products which are not manufactured by Seller and which are not an integral part of Seller's manufactured product, and a delay in the delivery of such products to Seller occurs that will cause a delay in Seller's performance date, Seller reserves the right to ship its product upon completion of manufacture and to refund an equitable portion of the amount originally included in the purchase price for mounting without incurring liability for non-performance.

D. Seller reserves to itself the right to change its specifications, drawings and standards if such changes will not impair the performance of its products, and parts, and further those products, and parts, will meet any of Buyer's specifications and other specific product requirements which are a part of this agreement. Seller is a global supplier of products and utilizes parts and products obtained worldwide, and Seller's products supplied under this contract shall be subject to Seller's sole determination as to all manufacturing, sourcing, assembly and supply unless otherwise specifically agreed in writing.

E. The manufacture and inspection of products and parts shall be to Seller's Engineering and Quality Assurance standards, plus such other inspections or tests of documentation as are specifically agreed to by Seller. Requirements for any additional inspection, tests, documentation, or Buyer witness of manufacture, test, and/or inspection shall be subject to additional charges.

4. TITLE AND RISK OF LOSS

Title and risk of loss shall pass to buyer upon delivery of products at the designated "Ex Works" as defined by Incoterms, unless other wise agreed by the parties.

5. EROSION AND CORROSION

It is specifically understood that products and parts sold hereunder are not warranted for operation with erosive or corrosive fluids or for operation with any fluid or under any operating condition in variance with the specifications of this contract. No product or part shall be deemed to be defective by reason of failure to resist erosive or corrosive action of any fluid and Buyer shall have no claim whatsoever against Seller therefore. No product shall be deemed defective by reason of any effect on Seller's products of the action or results (such as vibration) of any goods or system (such as piping) not supplied by Seller.

6. BUYER'S RESPONSIBILITY

The design specifications of the equipment require the operation of the equipment within certain parameters and may call for the use of speed controls, safety devices, set points or other control devices to insure that the operation remains within design parameters. Buyer agrees and understands

that the equipment must be operated and maintained within design specifications and operated within the specifications of the contract, irrespective of whether controls or devices are otherwise required.

7. WARRANTY AND LIMITATION OF LIABILITY

A. Seller warrants only that its product and parts, when shipped, will be free from defects in materials and workmanship. All claims for defective products or parts under this warranty must be made in writing immediately upon discovery and, in any event, within two (2) years of shipment by seller and all claims for defective work must be made in writing immediately upon discovery. Defective items must be held for Seller's inspection and returned to the sellers' point of original shipment upon request.

ANY UNAUTHORIZED DISSASSEMBLY, ALTERATION OF OR TAMPERING WITH ANY PRODUCT OR COMPONENT MAY "VOID" THE WARRANTY, IN THAT SUCH ACTION WILL RESULT IN SELLER BEING RELEASED AND RELIEVED FROM ITS OBLIGATIONS UNDER THIS WARRANTY AND FOR ANY FURTHER COSTS OR ACTIONS UNDER CLAUSE 7.C, FOLLOWING, AND THE BUYER ASSUMING SOLE RESPONSIBILITY FOR THE COSTS AND RESULTS OF SUCH ACTION. THE FOREGOING IS EXPRESSLY IN LIEU OF ALL OTHER WARRANTIES WHATSOEVER, EXPRESS, IMPLIED AND STATUTORY, INCLUDING WITHOUT LIMITATION, THE IMPLIED, WARRANTIES OF MERCHANTABILITY AND FITNESS.

B. ANY PRODUCT (S) SOLD HEREUNDER WHICH ARE NOT MANUFACTURED BY SELLER ARE NOT WARRANTED BY SELLER and shall be covered only by the express warranty, if any, of the manufacturer thereof. With respect to products and parts not manufactured by Seller, Seller's only obligation shall be to assign to Buyer, to the extent possible, whatever warranty Seller obtains from the manufacturer.

C. Upon Buyer's submission of a claim as provided above and its substantiation, Seller shall at its option either (i) repair or replace its product, part or work at the original place of shipment, or (ii) refund an equitable portion of the purchase price.

D. THE FOREGOING IS SELLER'S ONLY OBLIGATION AND BUYER'S EXCLUSIVE REMEDY FOR BREACH OF WARRANTY AND, EXCEPT FOR THE REMEDIES PERMITTED UNDER THE PERFORMANCE, INSPECTION AND ACCEPTANCE AND THE PATENTS CLAUSES HEREOF, THE FOREGOING IS BUYER EXCLUSIVE REMEDY AGAINST SELLER FOR ALL CLAIMS ARISING HEREUNDER OR RELATING HERETO WHETHER SUCH CLAIMS ARE BASED ON BREACH OF CONTRACT, TORT (INCLUDING NEGLIGENCE OR STRICT LIABILITY), INDEMNITY OR OTHER THEORIES. BUYER'S FAILURE TO SUBMIT A CLAIM AS PROVIDED ABOVE SHALL SPECIFICALLY WAIVE ALL CLAIMS FOR DAMAGES OR OTHER RELIEF, INCLUDING BUT NOT LIMITED TO CLAIMS BASED ON LATENT DEFECTS. IN NO EVENT SHALL BUYER BE ENTITLED TO INDIRECT, SPECIAL, INCIDENTAL OR CONSEQUENTIAL DAMAGES, NOR FOR DAMAGES FOR LOSS OF USE, LOST PROFITS OR REVENUE, INTEREST, LOST GOODWILL, WORK OR PRODUCTION STOPPAGE, IMPAIRMENT OF OTHER GOODS, INCREASED EXPENSES OF OPERATION, OR THE COST OF PURCHASING REPLACEMENT POWER OR OTHER SERVICES BECAUSE OF SERVICE INTERRUPTIONS. FURTHERMORE, IN NO EVENT SHALL SELLER'S TOTAL LIABILITY FOR DAMAGES OF BUYER EXCEED THE PURCHASE PRICE OF THE PRODUCTS OR PARTS MANUFACTURED BY SELLER AND UPON WHICH SUCH LIABILITY IS BASED. ANY ACTION ARISING HEREUNDER RELATED HERETO, WHETHER BASED ON BREACH OF CONTRACT, TORT (INCLUDING NEGLIGENCE) OR OTHER THEORIES, MUST BE COMMENCED WITHIN ONE (1) YEAR AFTER THE CAUSE OF ACTION ACCRUES OR IT SHALL BE BARRED.

8. PURCHASER'S REPRESENTATIONS & WARRANTIES

Purchaser represents and warrants that the products(s) covered by this contract shall not be used in or in connection with a nuclear facility or application. The parties agree that this representation and warranty is material and is being relied on by seller. This provision may be modified in a separate writing signed by an officer of Price Pump Co.

9. PATENTS

Seller agrees to assume the defense of any suit for infringement of any patents brought against Buyer to the extent of such suit charges infringement of an apparatus or product claim by Seller's product in and of itself, provided (i) said product is built entirely to Seller's design, (ii) Buyer notifies Seller in writing of the filing of such suit within ten (10) days after the service of process thereof, and (iii) Seller is given complete control of the defense of such suit, including the right to defend, settle and make changes in the product for the purpose of avoiding infringement of any process or method claims. Provided however, Seller will not defend any suit for infringement of a claimed patent where such alleged infringement is the result of following specific instruction furnished by Seller.

10. EXTENT OF SUPPLY

Only products as listed in Seller's proposal are included in this agreement. It must not be assumed that Seller has included anything beyond same.

11. MANUFACTURING SOURCES

To maintain delivery schedules, Seller reserves the right to have all or any part of the Buyer's order manufactured at any of Sellers', sellers' licensees or sub contractors' plants, globally.

12. TERMS OF PAYMENT

Net 30 days from date of invoice.

13. ARBITRATION

In the event a dispute arises between the parties relating to or arising out of this agreement, the parties agree to attempt to have their senior management amicably settle the matter. In the event that the matter cannot be settled, the parties shall submit all disputes relating to this Agreement (whether contract, tort, products liability or otherwise) to binding Arbitration before a panel of arbitrators under the Commercial Dispute Resolution Procedures of the American Arbitration Association. Each party shall appoint an arbitrator and the third shall be selected in accordance with the rules of the American Arbitration Association. Judgment upon the award may be entered in any court having jurisdiction. The parties shall cooperate in providing reasonable disclosure of relevant documents. Each party shall bear its own expenses, and the costs and fees of the arbitration shall be borne as allocated by the Arbitrator.